

EXCAVATOR LRE

VAN TUNEN 390 29M REACH



Rather have the digital version? Go to:
WWW.VANTUNEN.NL/RENTAL

EXCAVATOR 'SPECIAL' LRE TRIPLE BOOM

OPERATING WEIGHT
± 145 TONS

BUCKET
± 2.5 - 4.5 m³

OVERVIEW

“Load more, make more”

The new Van Tunen - Triple Boom with a reach of 29m meets your need to move more material at a lower cost, so you can achieve production targets, deliver on your commitments, meet deadlines - and maximize your profitability. The Most Powerful Engine in Its Class, Translating to Faster Cycle Times, and Greater Productivity. It still lift 10ton at full reach, take less space on your breakwater and with a raised cabine it is perfect to un-load your marine equipment.

PORTFOLIO



Undercarriage is designed for High-Impact and High-Travel Applications, Like Mining and Heavy Construction. This model is equipped with 900mm tracked shoes.

ATTACHMENTS



BUCKET

- HD GP bucket
- Skeleton buckets
- Coal handling bucket
- Extreme Duty Rock buckets
- Size: $\pm 2.5 \sim 4.5\text{m}^3$

GRAB

- Closed (environmental) or regular
- Size: $\pm 1.5 \sim 3.0\text{m}^3$



ORANGE PEEL GRAB

- Closed (environmental) or regular
- Size: $\pm 1.5 \sim 3.0\text{m}^3$



EXTENDER (HYDRAULIC)

Please note that we can extend the reach of the excavator for your project needs. Same as for all our attachments, we build or customize all these items at our Van Tunen yard. Please ask us for the possibilities.

FACTS & FIGURES



GENERAL INFORMATION



INFO	SPECS
Engine power	382KW 520hp
Baseboom length	6.9m
Topboom length	7.8m
Stick length	8.5m
Hydraulic extender	3-6.0m
Lifting capacity full reach	10tons
Fuel consumption	± 40-55 ltr/hr
Production:	Contact us

SHIPPING INFORMATION



TOOL	SPECS
Shipping height	± 3.8m
Shipping Length	± 14.5m
Shipping width (900mm tracks)	± 4.9m
Stick / extender	± 1x 40"ft cont.
Ground clearance	± 0.9m
Ground pressure	± 14.9N/cm ³
Max. weight	± 145 tons

SPECIALTIES



- Technical Support Van Tunen
- Safety check valves on boom, VA & stick cylinders
- Medium pressure function (rotator)
- High Pressure hydraulic function hamer / shear
- GPS / Survey on request

EXCAVATOR SPECIFICATIONS

WORKING RANGES

All dimensions are approximate.

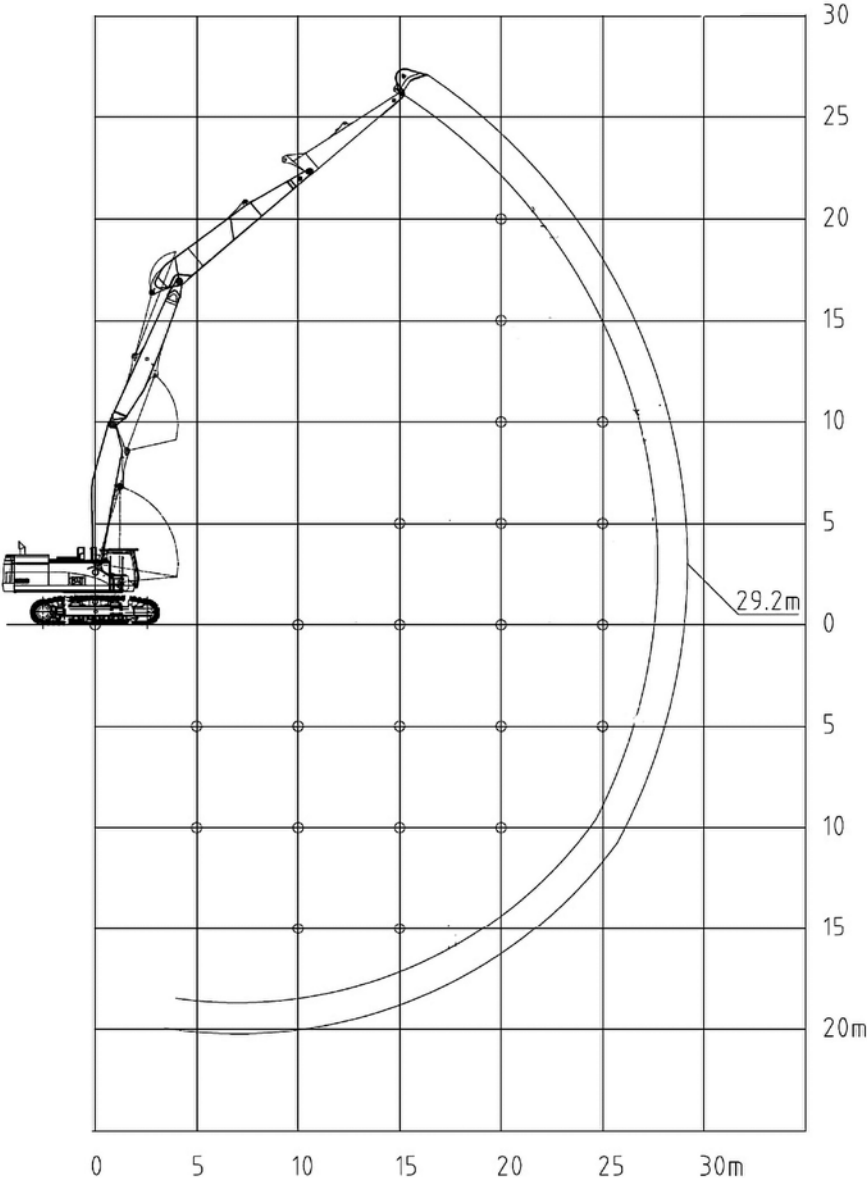

SAFETY FIRST - QHSE

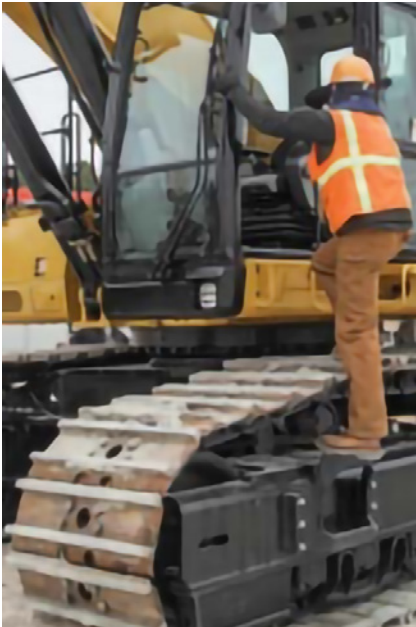

A SAFE, QUIET CAB

The ROPS cab provides you with a safe working environment. It also contributes to your comfort because it's attached to a reinforced frame with special viscous mounts that limit vibration and unnecessary sound. Add in special roof lining and sealing and you have a cab that's as quiet inside as any of today's top pickup trucks.

SECURE CONTACT POINTS

Multiple large steps get you into the cab as well as a leg up to the compartments. Extended hand and guard rails allow you to safely climb to the upper deck. Anti-skid plates reduce your slipping hazards in all types of weather conditions, and they can be removed for cleaning.

GREAT VIEWS

Ample glass gives you excellent visibility out front and to the side, and the standard rearview camera gives you a clear field of view behind the machine through the cab monitor. The available split-configuration windshield features an upper window with handles that make it easy to slide and store above you and a lower window that can be removed and stored on the inside wall of the cab. The large skylight also serves as an emergency exit and provides you with enhanced overhead visibility.

SMART LIGHTING

Halogen lights provide plenty of illumination, and the cab and boom lights can be programmed to stay on for up to 90 seconds after the engine has been turned off to help you safely exit the machine. Optional High Intensity Discharge (HID) lights are available for enhanced night-time visibility.



REQUIRE THIS MACHINE FOR YOUR PROJECT?

Please contact us for a competitive quotation or for further information about our customized solutions. Feel free to give us a call **+31 251 26 44 44**, send us an e-mail **info@vantunen.nl** or visit **www.vantunen.nl**

Experts in coastal development, earthmoving, rock works and mining

Van Tunen provides worldwide rental of heavy earthmoving equipment and technical project support services for the dredging, earthmoving and mining industry as well as the maritime sector. From harbour improvement to coastal protection, from pipeline works to demolition, depend on our team for solid advice, made-to-measure solutions and prompt support.

Get to know us, please visit:

www.vantunen.nl



Contact us

+31 251 26 44 44
info@vantunen.nl
www.vantunen.nl

Visit us

Zuiderkade 9
1948 NG Beverwijk
The Netherlands

About us

Registration nr. 34056786
VAT nr. NL00 706 8797 B01