

EXCAVATOR LRE

VAN TUNEN 6015B 35M REACH



Rather have the digital version? Go to:
WWW.VANTUNEN.NL/RENTAL

EXCAVATOR 'SPECIAL' LRE TRIPLE BOOM

OPERATING WEIGHT
± 200 TONS

BUCKET
± 3.0 - 6.5 m³

OVERVIEW

“Load more, make more”

The new Van Tunen 6015B Triple Boom meets your need to move more material at a lower cost, so you can achieve production targets, deliver on your commitments, meet deadlines - and maximize your profitability. The Most Powerful Engine in Its Class, Translating to Faster Cycle Times, and Greater Productivity.

PORTFOLIO



Undercarriage is designed for High-Impact and High-Travel Applications, Like Mining and Heavy Construction. This model is equipped with 1000mm tracked shoes.

ATTACHMENTS



BUCKET

- HD GP bucket
- Skeleton buckets
- Coal handling bucket
- Extreme Duty Rock buckets
- Size: $\pm 3.0 \sim 6.5\text{m}^3$

GRAB

- Closed (environmental) or regular
- Size: $\pm 1.5 \sim 3.5\text{m}^3$



ORANGE PEEL GRAB

- Closed (environmental) or regular
- Size: $\pm 1.5 \sim 3.5\text{m}^3$



EXTENDER (HYDRAULIC)

Please note that we can extend the reach of the excavator for your project needs. Same as for all our attachments, we build or customize all these items at our Van Tunen yard. Please ask us for the possibilities.

FACTS & FIGURES



SPECIALTIES



- Technical Support Van Tunen
- Safety check valves on boom, VA cylinders
- Medium pressure function (rotator)
- High Pressure hydraulic function hammer / shear
- GPS / Survey on request

DIMENSIONS

Shipping Module dimensions and weights. All dimensions are approximate.

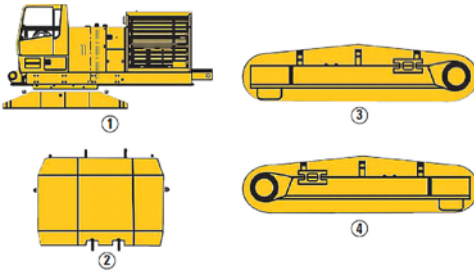

Modules	Length		Width		Height		Weight	
	mm	in	mm	in	mm	in	kg	lb
Long Undercarriage (GP) Configuration								
1 Chassis, Carbody and Cab	7070	278	3500	138	3560	140	43 300	95,390
2 Counterweight	900	35	3770	149	2630	103	16 800	37,000
3 Track Roller Frames ¹ – Long (R)	7110	280	1450	57	1800	71	22 724	50,061
4 Track Roller Frames ¹ – Long (L)	7110	280	1450	57	1800	71	22 724	50,061
5 Handrail Skid	3990	157	1120	44	2290	90	1340	3,000
Parts Box	2240	88	990	39	1090	43	1550	3,400
6 Bucket Assembly ²	7688	303	2612	103	1977	78	12 866	28,344
Bucket – 6.0 m ³	2790	110	2612	103	1905	75	5316	11,711
Bucket Assembly ²	8500	335	2286	90	2054	81	13 105	28,870
Bucket – 5.0 m ³	2630	104	2286	90	1900	75	4787	10,546
Bucket Assembly ²	9585	377	1980	78	1900	75	16 483	36,312
Bucket – 4.2 m ³	2850	112	1980	78	1900	75	7370	16,236

¹ Includes 900 mm (35 in) shoes with center and end guides.

² Includes tips (penetration).

GENERAL INFORMATION



INFO	SPECS
Engine power	606KW 813hp
Baseboom length	11.6m
Topboom length	11.5m
Stick length	10.2m
Lifting capacity full reach	14tons
Fuel consumption	± 60-80 ltr/hr
Production	Contact us

SHIPPING INFORMATION



TOOL	SPECS
Shipping height	± TBD
Shipping Length	± TBD
Max. width (1000mm tracks)	± TBD
Ground clearance	± TBD
Ground pressure	± 18.3 N/cm ³
Max. weight	± 200 tons

EXCAVATOR SPECIFICATIONS

WORKING RANGES

All dimensions are approximate.

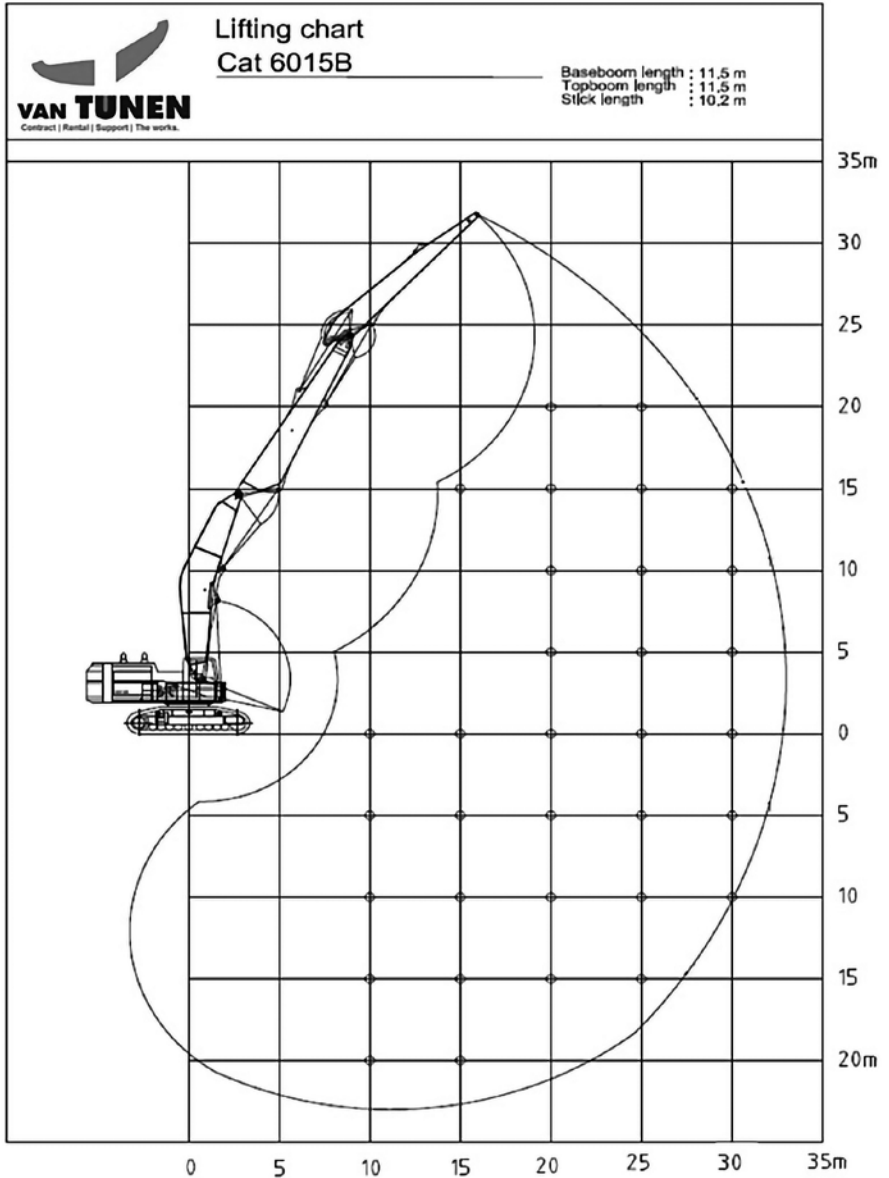

SAFETY FIRST - QHSE



OPERATOR ENVIRONMENT

- Optimized operator situational awareness and safe machine positioning via excellent cab visibility and large, ideally positioned mirrors.
- Multiple egress points for safe exit to the side or front of machine.
- Cab equipped with emergency hammer for quick escape and ready access to emergency ladder.
- Numerous, optimally positioned lights for ample visibility during operation in dark conditions.
- Safety glass windshield.
- Ergonomic placement of cab door handle to prevent bending down, and risk of injury, to enter cab.
- Sounds Suppression Reduced operator and spectator sound levels result in less impact on the communities where the 6015B operates. The 6015B cab provides the operator with a quiet work environment.

MACHINE ACCESS

- Wide crosswalk made of extruded tread plates provides safer service access to full width of machine, including hydraulics, engine service doors and engine/pump room.
- Safe movement about the machine via wide and slip-resistant walkways, limited walkway elevation changes (steps up/down), and minimized trip hazards.
- Grab irons and steps provide operator and maintenance personnel with three points of contact at all times.
- Quick exit from machine during emergency facilitated by three means of egress.

ELECTRICAL SYSTEM

- Safe electrical maintenance facilitated by battery disconnect switch. Emergency Shut-Offs
- Ground level, engine and pump room, and cab access to engine kill switches allows quick shutoff in emergency situations.





REQUIRE THIS MACHINE FOR YOUR PROJECT?

Please contact us for a competitive quotation or for further information about our customized solutions. Feel free to give us a call **+31 251 26 44 44**, send us an e-mail **info@vantunen.nl** or visit **www.vantunen.nl**

Experts in coastal development, earthmoving, rock works and mining

Van Tunen provides worldwide rental of heavy earthmoving equipment and technical project support services for the dredging, earthmoving and mining industry as well as the maritime sector. From harbour improvement to coastal protection, from pipeline works to demolition, depend on our team for solid advice, made-to-measure solutions and prompt support.

Get to know us, please visit:

www.vantunen.nl



Contact us

+31 251 26 44 44
info@vantunen.nl
www.vantunen.nl

Visit us

Zuiderkade 9
1948 NG Beverwijk
The Netherlands

About us

Registration nr. 34056786
VAT nr. NL00 706 8797 B01