

EXCAVATOR LRE

VAN TUNEN

EX1900.6 40M REACH



Rather have the digital version? Go to:

WWW.VANTUNEN.NL/RENTAL

EXCAVATOR 'SPECIAL' LRE TRIPLE BOOM

OPERATING WEIGHT
± 320 TONS

LIFTING CAPACITY FULL REACH
± 20 TONS



OVERVIEW

“Load more, make more”

The Van Tunen EX1900-6, are engineered to give you efficiency, reliability and durability for all kinds of jobs. You get strong horsepower, efficient engines, comfortable cabs, advanced hydraulics, tough frames, powerful arm and bucket-digging forces and more. When you choose the EX1900-6, you get a world class excavator.

PORTFOLIO



Optional folding stairs with wide steps allow for easy accessibility servicing and maintenance



A walkway around the entire counterweight provides easy access for faster, safer inspections and maintenance

There is a centralized filter system that makes inspection and maintenance quicker and more convenient. And the contamination sensor alerts the operator before it's too late of accumulated contaminants in the oil that could cause damage.

ATTACHMENTS



BUCKET

- HD GP bucket,
- Skeleton buckets.
- Coal handling bucket.
- Extreme Duty Rock buckets.
- Size: $\pm 2.5 - 12.0\text{m}^3$

ORANGE PEEL GRAB

- Closed (environmental) or regular
- Size: $\pm 1.5 - 4.5\text{m}^3$



GRAB

- Closed (environmental) or regular
- Size: $\pm 2.5 - 8.5\text{m}^3$



EXTENDER (HYDRAULIC)

Please note that we can extend the reach of the excavator for your project needs. Same as for all our attachments, we build or customize all these items at our Van Tunen yard. Please ask us for the possibilities.

FACTS & FIGURES



SPECIALTIES



- Technical Support Van Tunen
- Safety check valves on boom
- Medium pressure function (rotator)
- High Pressure hydraulic function hamer / shear
- GPS / Survey on request

DIMENSIONS

All dimensions are approximate.

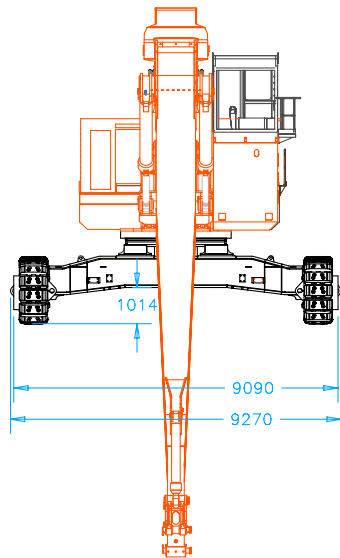
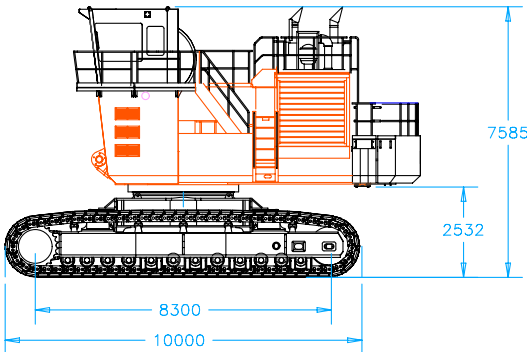

GENERAL INFORMATION



INFO	SPECS
Engine power	810KW 1086hp
Boom length	± 13m
Topboom length	± 11.5m
Stick length	± 14.2m
Lifting capacity full reach	± 20 tons
Fuel consumption	± 60-80 ltr/hr
Production	Contact us

SHIPPING INFORMATION



TOOL	SPECS
Shipping height	± TBD
Shipping Length	± TBD
Shipping width (850mm tracks)	± TBD
Ground clearance	± TBD
Max. weight	± 320 tons

EXCAVATOR SPECIFICATIONS

WORKING RANGES

All dimensions are approximate.

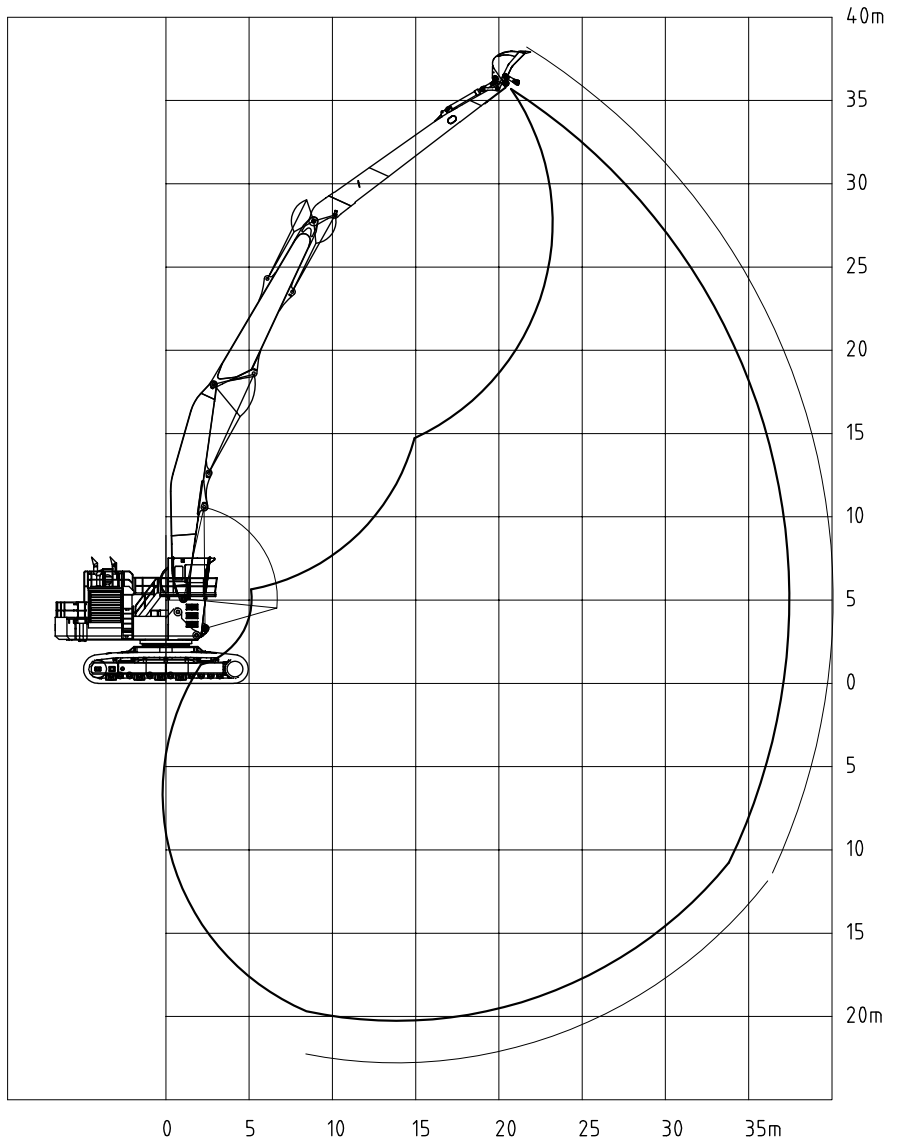

SAFETY FIRST - QHSE



OPERATOR ENVIRONMENT

The ROPS cab provides you with a safe working environment. It also contributes to your comfort because it's attached to a reinforced frame with special viscous mounts that limit vibration and unnecessary sound. Add in special roof lining and sealing and you have a cab that's as quiet inside as any of today's top pickup trucks.

MACHINE ACCES

The wide crosswalk made of extruded tread plates provides safer service access to full the width of the machine, including hydraulics, engine service doors and engine/pump room. Safe movement about the machine via wide and slip-resistant walkways with limited walkway elevation changes (steps up/down), and minimized trip hazards. Grab irons and steps provide operator and maintenance personnel with three points of contact at all times. There is a quick exit from the machine during an emergency facilitated by three means of egress.

ELECTRICAL SYSTEM

Safe electrical maintenance facilitated by a battery disconnect switch. Emergency Shut-Offs exists on ground level, in the engine and pump room, and cab. Access to engine kill switches allows quick shutoff in emergency situations.



REQUIRE THIS MACHINE FOR YOUR PROJECT?

Please contact us for a competitive quotation or for further information about our customized solutions. Feel free to give us a call **+31 251 26 44 44**, send us an e-mail **info@vantunen.nl** or visit **www.vantunen.nl**

Experts in coastal development, earthmoving, rock works and mining

Van Tunen provides worldwide rental of heavy earthmoving equipment and technical project support services for the dredging, earthmoving and mining industry as well as the maritime sector. From harbour improvement to coastal protection, from pipeline works to demolition, depend on our team for solid advice, made-to-measure solutions and prompt support.

Get to know us, please visit:

www.vantunen.nl



Contact us

+31 251 26 44 44
info@vantunen.nl
www.vantunen.nl

Visit us

Zuiderkade 9
1948 NG Beverwijk
The Netherlands

About us

Registration nr. 34056786
VAT nr. NL00 706 8797 B01